

# Technical Vision of Slicing Packet Network (SPN) for 5G Transport

(Version 1.0)

## Contact Information

Tel: +86 158 0169 6688

E-mail: [chengweiqiang@chinamobile.com](mailto:chengweiqiang@chinamobile.com)

Reviewed by: Han LI

Copyright: China Mobile Communications Corporation



February , 2018

China Mobile Communications Corporation

# Contents

<b>1 Requirements and Vision .....</b>	<b>1</b>
1.1 Driving Force .....	2
1.1.1 Wireless Services .....	2
1.1.2 Residential Services.....	3
1.1.3 Enterprise Services.....	4
1.1.4 DCI Services.....	4
1.2 Key Requirements for new Transport Networks .....	5
1.3 SPN Vision .....	6
<b>2 Principles and Architecture .....</b>	<b>7</b>
2.1 SPN Design Principles.....	8
2.2 Technical Architecture.....	9
<b>3 Key Technologies.....</b>	<b>13</b>
3.1 Slicing Ethernet .....	14
3.1.1 Slicing Ethernet Requirements .....	14
3.1.2 Slicing Ethernet Technology.....	15
3.2 Efficient High-Bandwidth Technology.....	17
3.2.1 Efficient High-Bandwidth Requirements .....	17
3.2.2 Efficient High-Bandwidth Technology.....	17
3.3 Deterministic Low Latency Technology .....	19
3.3.1 Slicing Packet Deterministic Low Latency Technology.....	19
3.3.2 Slicing Ethernet Deterministic Low Latency Technology.....	20

- 3.4 Flexible and Reliable Connection Technology ..... 22
  - 3.4.1 Flexible Connection Requirements.....22
  - 3.4.2 Flexible Connection Technology .....22
- 3.5 Ultra-High Precision Synchronization Technology ..... 23
  - 3.5.1 High-Precision Time Synchronization Requirements .....23
  - 3.5.2 SPN Time Synchronization Network Model.....24
  - 3.5.3 Ultra-High Precision Synchronization Technology for the SPN .....25
- 3.6 Centralized Management and Control Technology of SDN ..... 27
  - 3.6.1 Requirements.....27
  - 3.6.2 Key Technologies for Intelligent Operations.....28
  - 3.6.3 Architecture of the Intelligent Operating System.....30
- 4 Application Scenarios ..... 33**
  - 4.1 Mobile Service Transport ..... 34
    - 4.1.1 Fronthaul Network.....34
    - 4.1.2 Midhaul/Backhaul Network.....35
  - 4.2 Data Center Interconnection ..... 35
    - 4.2.1 Multi-point Interconnection Between Edge DCs over the SPN.....36
    - 4.2.2 Point-to-Point Interconnection Between DCs over the SPN .....36
  - 4.3 Video Everywhere ..... 37
  - 4.4 Cloud Private Line..... 38
    - 4.4.1 Cloud Connection.....38
    - 4.4.2 Cloud Application.....39
- 5 Summary and Prospect ..... 41**

# 1

## Requirements and Vision

As 4G has profoundly changed people’s life, 5G will further bring fundamental changes to the society. It is expected that a fully mobile and connected world will be performed. In particular, networks are and will always be the cornerstone with the rapid development of the information era. The 5G transport network should be a part of a converged multi-service network that supports wireless services, residential services, enterprise services, and Data Center Interconnect (DCI) services.

## 1.1 Driving Force

### 1.1.1 Wireless Services

3GPP has defined three typical scenarios of 5G, namely eMBB (enhanced Mobile Broadband), URLLC (Ultra-high Reliability, Low Latency Communication) and mMTC (massive Machine Type of Communication). These new applications will bring great challenges to the transport network as follows:

#### Traffic rate will grow 1000 times

It is estimated that the total global mobile data traffic will be up to 1000 times from 2010 to 2020. The corresponding throughput will reach 100 Gbit/s per square kilometer, which is also required to grow 1000 times.

#### Number of connections will increase 100 times

With the rapid development of the Internet of Things (IoT), the total number of devices connected by the mobile network will be between 50 and 100 billion by 2020. Thus, the connection density will also be increased significantly. In several cases, the connection density of 5G mobile networks will reach 1 million/km<sup>2</sup>, which is 100 times larger than that of 4G networks.

#### 10 Gbit/s peak data rate

Nowdays, the peak data rate of 4G networks is around 1 Gbit/s. In the 5G era, this rate will be improved to 10 Gbit/s to meet the user requirements.

#### 10 Mbit/s user experienced data rate

In 2020, the user experienced data rate will be larger than 10 Mbit/s in the vast majority of cases. Furthermore, the 5G network could provides 100 Mbit/s data rate for several high-priority services, such as HD medical image transmission in emergency vehicles.

#### Lower latency and higher reliability

Compared with 4G, 5G should have 5 to 10 times of decrease in the latency from the terminal device to the core network. Moreover, for the services related to human life and property security, the E2E reliability should be increased to 99.999%.

#### Improved spectral efficiency

According to ITU, the minimum value of the mean spectral efficiency in outdoor for IMT-A should be 2 bps/Hz to 3 bps/Hz. To resolve the shortage of spectral resources caused by explosive growth on traffic, the mean spectral efficiency of 5G should be 5 to 10 times higher than that of 4G.

Figure 1-1: 5G system requiring new transport networks

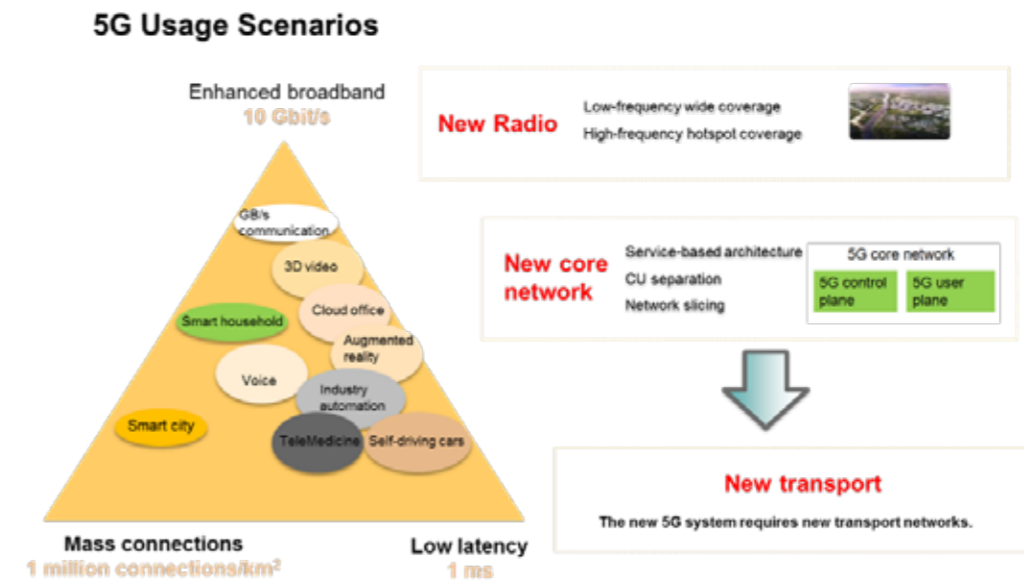

### 1.1.2 Residential Services

With the rapid development of new services, such as 4K/8K video, virtual reality (VR)/augmented reality (AR), IoT, Big Data, Industry 4.0, and artificial intelligence (AI), etc., existing residential broadband is faced with enormous challenges. As people’s desire for better experience is never-ending, it will further drive up the quality of residential broadband. However, there is still an obvious performance

difference between the user-experienced bandwidth and the subscribed bandwidth, especially in a Wi-Fi network. To pursue better experience, video service will have more strict requirements on transmission rate and latency. In addition, carriers have spent so much time on service provisioning and failure processing, resulting in degradation of user experience. Cloud-based strategies could be introduced to improve the management efficiency.

### 1.1.3 Enterprise Services

For government and enterprise customers, carriers provide broadband access and lease line services among different nodes. The rapid development of the IT industry will exhaust the bandwidth of the existing enterprise private lines in the near future and promote continuous demand on high-speed private lines. For different scenarios, there are three main types of private lines: IDC interconnection private line, high-value government and enterprise private line, and small and medium enterprise private line. Cloud services are benefit to enhance the management capability of private lines. Meanwhile, the clouded MEC will be further allocated toward the edge of the network which will bring tremendous challenges to the transport network. Simple bandwidth leasing cannot satisfy the requirements of large enterprises. Compared with the traditional private line service, virtual network leasing may be a promising way in the future.

### 1.1.4 DCI Services

The DC-based network architecture will change the traditional traffic model of the transport network. The transport network should support more flexible flows and diversified reliability. It is noted that the SDN technology is the key part of DCI services. The controller should achieve the WAN level interconnection between DCs and the orchestrator should realize resource scheduling across DCs. The SDN technology also supports forwarding and control of element separation and centralized routing computation.

## 1.2 Key Requirements for New Transport Networks

The advent of the digital society will exert profound influence on the communications infrastructure network, and the traffic model of the existing communications network will change dramatically. The connection density and traffic density will increase at an unprecedented rate and the geographical network coverage will be greatly extended. Users of different types pose personalized requirements on networks, and the requirements for real-time interaction of specific industries are extremely high. Therefore, the next-generation transport network architecture must meet the following requirements:

**High bandwidth:** The transport network needs to provide low-cost and high-bandwidth capabilities. The throughput capability should be larger than 1 Gbit/s per user, and the network should support the continuous development of video, holographic, and VR applications.

**Low latency:** It should support an E2E latency better than 1 ms to meet the stringent requirements of interactive experience and industrial control.

**Flexible connection:** The total number of connections has increased by several dozen times, and the new network should satisfy Full-Mesh data connection in the huge network with more than 10,000 nodes.

**Network openness:** It should support standardized southbound interface and northbound interface. In this manner they have the potential of leveraging the versatility and openness of the SDN control plane for implementation of the service control they are generating in either a virtual or a physical deployment or both.

**Network slicing:** Diversified services bring about diversified network requirements. In the future, the transport network should be equipped with dynamic network slicing capabilities to meet diversified service requirements. The network should provide the capability of both hard isolation and soft isolation.

**High reliability:** It should provide ultra-high reliability connections for new services such as AR, industrial control, and telemedicine.

**Intelligent O&M:** The service model changes fundamentally. Network slicing and Full Mesh traffic require a more intelligent network O&M system to reduce the OPEX.

### 1.3 SPN Vision

Slicing packet network (SPN) focuses on building an efficient, simplified, and ultra-broadband transport network to support the deferent services on the metro network.

**New architecture:** The new technology architecture provides a low-cost and simplified transport network. The bandwidth of the network is 100 times higher, and the cost per a single bit is 10 to 100 times less.

**New services:** SPN focuses on the support for new services on the transport network. The latency is 10 to 100 times less, and the number of service connections is 100 times greater.

**New operations:** The brand new O&M platform provides agile service deployment and operation capabilities. The OPEX is 10 times lower.

The SPN is positioned as a next-generation converged transport network based on the Ethernet ecosystem to implement comprehensive service transport with high bandwidth, low latency, and high efficiency.

The SPN carries the following services: wireless services, enterprise services, residential services, and cloud interconnection services.

## 2

## Principles and Architecture

## 2.1 SPN Design Principles

The SPN takes advantage of efficient Ethernet ecosystem to provide low-cost and high-bandwidth transport network services. With the efficient convergence of multi-layer network technologies, flexible soft isolation slicing and hard pipe slicing are implemented, and multi-layer service transport capabilities from L0 to L3 are all provided. SDN centralizes management and control to innovatively implement open, agile, and efficient network operations. SPN principles are as follows:

- **Packet friendly:** Drawing on Ethernet technology (IEEE 802.3 Ethernet, OIF FlexE, and innovative slicing Ethernet), the SPN shares the IP/Ethernet ecosystem (optical modules, protocols and chipsets), and support mainstream packet clients friendly.
- **Multi-layer network technology convergence:** With the efficient convergence of IP, Ethernet, and optical technologies, hierarchical networking at L0 through L3 can be implemented to allow for the construction of various types of pipes. Ethernet packet scheduling is used for flexible connections of packet services. Innovative slicing Ethernet data unit stream scheduling is used to support hard pipe isolation and bandwidth guarantee for services and provide low-latency service transport network channels. Optical-layer wavelength grooming is used to support smooth capacity expansion and large-granularity service grooming.
- **Highly efficient soft and hard slicing:** Both highly reliable hard slicing and elastic scalable soft slicing capabilities are provided. Such capabilities isolate resources of a physical network to run multiple virtual networks and provide differentiated SLA-based transport network services for multiple types of services.
- **SDN centralized management and control:** SDN helps implement open, agile, and efficient network operations and maintenance. Service provisioning and O&M are automated. SPN can monitor network status and trigger network self-optimization in real time. In addition, the architecture with converged SDN-based management and control provides the other capabilities, such as simplified network protocols and open networks, as well as cross-network domain and cross-technology service coordination.
- **Carrier-grade reliability:** Network-level hierarchical OAM and protection capabilities are supported. OAM is used to monitor logical layers, network

connections, and services on the network, which implements all-round network reliability and supports high-reliability service transport.

- **High-precision synchronization:** In-band clock and time synchronization-based transmission is implemented, with high reliability, high precision, and high efficiency.
- **Flexible service scheduling:** The SPN uses flexible tunneling, addressing, and forwarding techniques to flexibly schedule P2P, P2MP, and MP2MP services. Slicing Ethernet addressing and forwarding are used to implement Layer 1 service scheduling. MAC and MPLS addressing and forwarding are used to implement Layer 2 service scheduling. IP addressing and forwarding are used to implement Layer 3 service scheduling

Figure 2-1: SPN network architecture

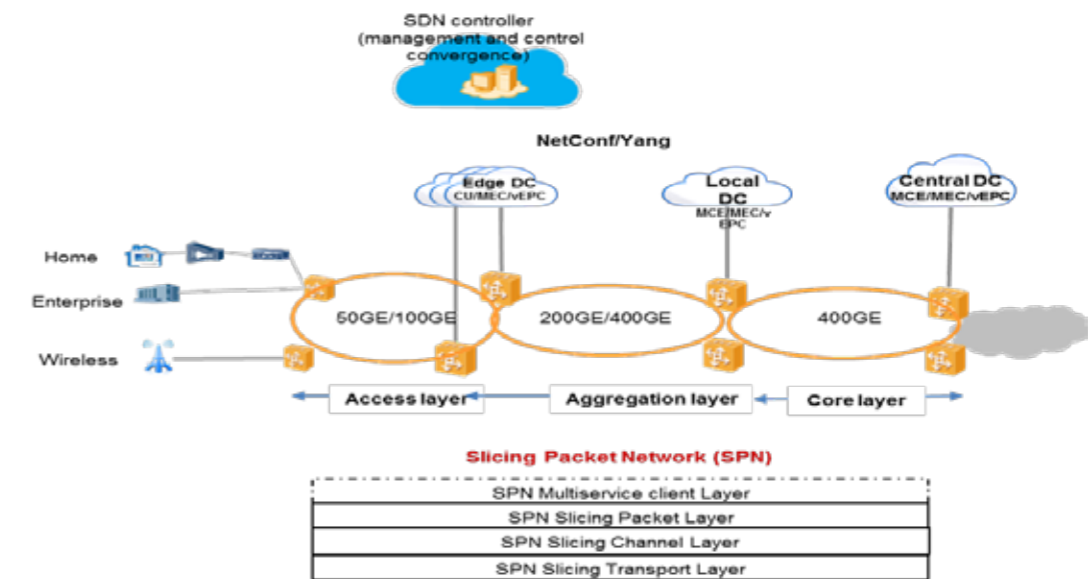

## 2.2 Technical Architecture

Based on the ITU-T network model, the SPN uses Ethernet as the basic technology and supports the integrated transport of IP, Ethernet, and constant bit rate (CBR) services. The SPN technology architecture consists of the slicing packet layer (SPL), slicing channel layer (SCL), slicing transport layer (STL), time and clock synchroniza-

tion module, and management and control function module.

**Figure 2-2:** Layered SPN network model

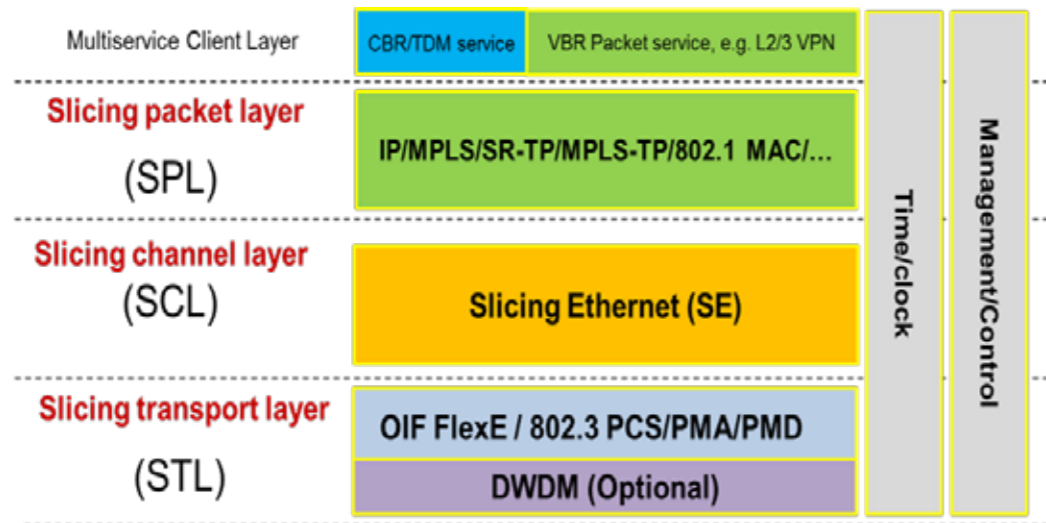

- **SPL:** By implementing addressing, forwarding, and transport channel encapsulation for IP, Ethernet, and CBR services, the SPL provides various types of services, such as Layer 2 virtual private network (L2VPN), L3VPN, and CBR transparent transport. The SPL performs service mapping using multiple addressing mechanisms, such as IP, Multiprotocol Label Switching (MPLS), 802.1q, and physical ports, and provides service identification, traffic engineering, and quality of service (QoS) guarantee. For packet services, the SPL provides the segment routing-transport profile (SR-TP) tunnels and provides both connection-oriented and connectionless transport channels. The source-route-based segment routing technique allows the ingress to use a set of segments (MPLS labels) to identify each tunnel forwarding path. Unlike conventional tunneling technologies, transit nodes do not need to maintain path status information for segment routing tunnels, which allows for flexible path adjustment and network programmability. SR-TP tunneling technology enhances O&M capabilities of SR tunnels and supports bidirectional tunnels and E2E service-level OAM detection.
- **SCL:** provides E2E channelized group channels for network services and slices. The SCL uses innovative slicing Ethernet (SE) to implement timeslot processing on Ethernet physical interfaces and FlexE bonding groups,

provide E2E Ethernet-based virtual network connections, and establish low-latency and hard isolated slicing channels for multi-service transport at L1. Drawing on OAM and protection functions for slicing Ethernet channels, the SCL implements E2E performance monitoring and failure recovery.

- **STL:** uses IEEE 802.3 Ethernet physical layer technology and OIF FlexE technology to implement efficient high-bandwidth transmission. The Ethernet physical layer is composed of new high-speed Ethernet interfaces, such as 50GE, 100GE, 200GE, and 400GE. By virtue of the Ethernet industry chain, low-cost and high-bandwidth network construction is implemented, and mainstream networking applications with up to 80 km between hops are supported. For applications that require higher bandwidth scalability and longer transmission distance, the SPN uses the Ethernet+DWDM combination to implement networking of the 10T-scale capacity and hundreds of kilometers of long distances.





## 3.1 Slicing Ethernet

### 3.1.1 Slicing Ethernet Requirements

The future multiple services (such as 5G eMBB, URLLC, and mMTC) support raised the end-to-end network slicing requirement for the future transport network. Different services of different industry have differentiated requirements could be supported by different QOS guaranteed network technologies (e.g. Packet/TDM). The end-to-end sliceable future transport network with allocated isolated network resource should be able to prevent negative impact of adding new service to the existing network and thus reduce operation costs.

Network slicing enables relevant service functions and network resources of a physical network to be organized together to form multiple completely separated, autonomous, and independent logical network slices, with each slice meeting specific user/service requirements.

The high-bandwidth, massive-connection, and low-latency services pose higher requirements on the transport network. Effectively isolating transport network resource to satisfy differentiated SLA requirements of various services is a new challenge for the future-proof transport network. Current slicing/isolation mechanism can be classified as soft slicing/isolation and hard slicing/isolation. Packet based (e.g. MPLS) VPN technology is considered as an efficient solution for soft slicing/isolation in packet transport network with statistical multiplexing capability. However, packet based VPN technology as a soft slicing/isolation mechanism cannot solve the bandwidth preemption problem of different services and cannot guarantee the SLA of the services. Especially in the case of considering improve bandwidth utilization, many data center networks use the jumbo packet technique, which prolongs packet scheduling between slices and adversely affects the SLA capability for the other slices. The IP/Ethernet friendly future multiservice transport network need to be enhanced with hard slicing/isolation capability. Ethernet has become the mainstream technology for its simplicity, high efficiency, and low cost, the hard slicing/isolation mechanism should be Ethernet based.

### 3.1.2 Slicing Ethernet Technology

There are some efforts in the industry Ethernet based hard slicing/isolation. For example, FlexE and previous MLG developed by OIF provide a hard slicing/isolation mechanism based on Ethernet physical interfaces. However, FlexE as an interface-level technique at this stage have no end-to-end networking consideration to meet the carrier network requirements. In the SPN architecture, an innovative new network layer, the Slicing Ethernet (SE) is proposed to provide Ethernet based slicing/isolation capability. Slicing Ethernet prevents L2/L3 packet storage and table lookups, provides end-to-end hard isolated pipe Layer 1 networking capability with node low latency. Slicing Ethernet (SE) has the following features:

- **Slicing Ethernet cross-connect (SE-XC):** Supports extremely low node forwarding latency and hard isolation for services. Providing end-to-end SPN Slicing Ethernet Channels and support E2E Ethernet L1 networking.
- **On-demand E2E OAM:** The on-demand Slicing Ethernet OAM&P messages replacing Ethernet IPG idle blocks are used for supporting strong and good enough OAM and protection functions in an end-to-end Slicing Ethernet Channels based on requirement and configuration. E2E protection switching can be implemented within 1 ms, and system bit error detection can be performed as required.
- **Transparent mapping of CBR services:** Specific transcoding and data rate adjusting mechanism is used to transparently map various services into Slicing Ethernet channels, over which Ethernet and/or non-Ethernet CBR services could be transparently transmitted.

Figure 3-1: Slicing Ethernet technology

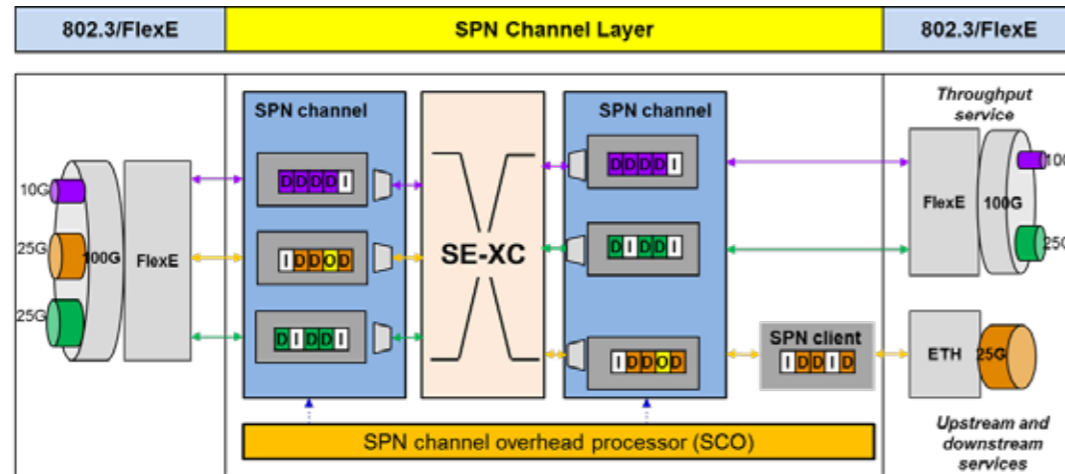

Slicing Ethernet L1 networking technique is an effective enhancement to the L2 Ethernet L2.5 MPLS and IP L3 networking. With the introduction of Slicing Ethernet, the SPN has the Ethernet-based multi-layer networking capability and satisfies differentiated multiservice transport requirements. End-to-end SPN Slicing Ethernet Channels are used for high-value private lines. Layer 2 or Layer 3 per packet scheduling and/or soft tunnels which support packet statistics multiplexing is used to achieve efficient bandwidth utilization. For low-latency packet services, Layer 2 and Layer 3 packet scheduling could be limited at edge PE nodes, on P nodes within the network Slicing Ethernet cross-connecting (SE-XC) at Layer 1 could rapidly forward packets of the same SPN Slicing Ethernet Channels with low latency.

Figure 3-2: Slicing Ethernet application

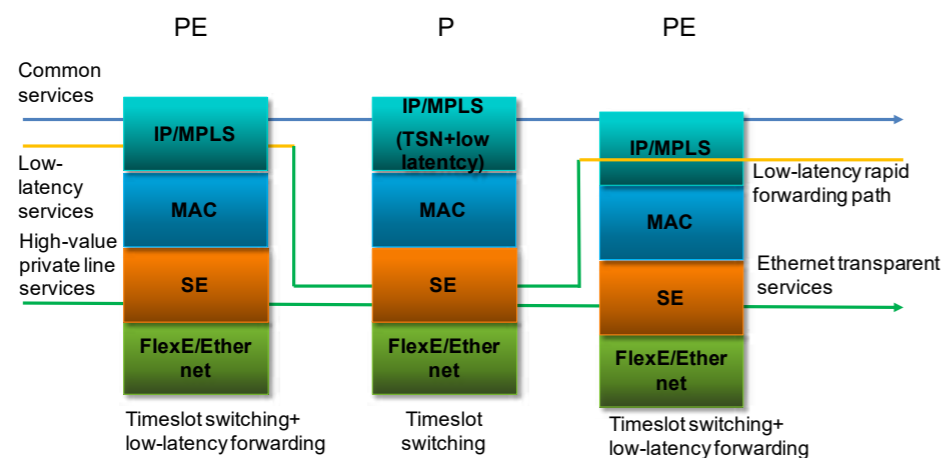

### 3.2 Efficient High-Bandwidth Technology

#### 3.2.1 Efficient High-Bandwidth Requirements

With the rapid development of 5G mobile, HD video, data center interconnection, and IoT services, the bandwidth of transport networks will grow rapidly. The 5G mobile New Radio (NR) uses wider spectrum and higher spectral efficiency to provide bandwidth experience at a peak rate of 10 Gbit/s for each cell, improved by 100 times compared with 4G mobile networks. With the development of 4K, 8K, and VR video services, the bandwidth requirement of a single user will increase to 100 Mbit/s to 1 Gbit/s. Thus the transport network urgently requires new efficient technologies to accommodate service bandwidth development demands. In addition, the average revenue per user (ARPU) of a single user cannot be increased greatly. Therefore, the bandwidth growth should not increase network construction costs largely.

The Ethernet interface is the most widely used interface technique in the communications field. It is also the most cost-effective interface. After nearly four decades of development, Ethernet interfaces have formed a mature industry chain and have been widely used on telecom and IT networks. Owing to the development of the Internet, high-speed Ethernet interfaces have been developed rapidly in recent years to meet ever-increasing service bandwidth requirements.

#### 3.2.2 Efficient High-Bandwidth Technology

Driven by requirements and technologies, the physical layer of Ethernet interfaces, the low-cost single-channel technique, and the high-performance multi-channel technique are developed at the same time to achieve optimal cost-effectiveness. The 50GbE, 200GbE, and 400GbE rates with the four-level pulse amplitude modulation (PAM4) and 25G optical components gradually become the mainstream next-generation Ethernet interfaces.

Figure 3-3: Ethernet port rate evolution

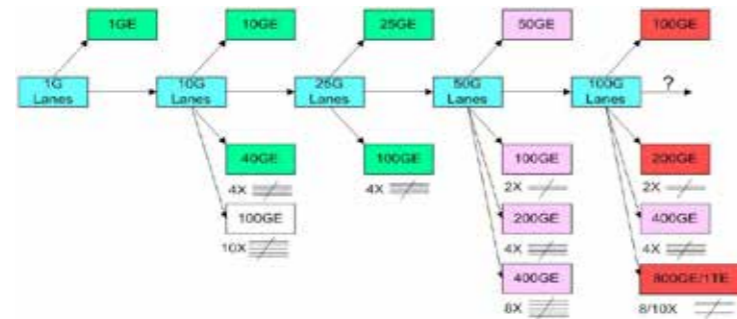

Based on 25G optical components and key technologies such as forward error correction (FEC) and PAM4, the rate is doubled, achieving the Lane 50 Gbit/s data rate and reducing the cost per bit. On the basis of 50GE over a single lane, the multi-lane mode is used to develop low-cost high-speed Ethernet interfaces, such as 200GE and 400GE. PAM4-based high-speed Ethernet technique standards, including 50GE, 200GE, and 400GE standards, have been developed in 802.3bs (200GE and 400GE) and 802.3cd (50GE). The standards will be released in 2018, which are widely recognized by the whole industry.

The 50GE, 200GE, and 400GE interfaces involve the following key technologies:

1. FEC: The mature KP4 FEC technique is implemented for long-distance transmission.
2. PAM4: PAM4 is used to double the data rate when the baud rate remains unchanged, and effectively reduces the cost of optical interfaces.

Proposed in 2014, FlexE was expected to apply to DCI whose main requirement is to decouple the MAC layer data rate from the PHY layer data rate. FlexE supports flexible mapping between MAC and PHY layers and the bonding of multiple PHYs, and implements various high-bandwidth interfaces. In the transport network field, FlexE is primarily used to provide variable data rates, which matches available bandwidth values on a network and support multi-wavelength applications, and saves optical fibers.

On an SPN network, FlexE bonds multiple optical interfaces and provides high-rate Ethernet interfaces based on a low-cost low-rate optical module. For example, four 200GE Ethernet interfaces are bonded to provide the 800 Gbit/s capacity on a single port. In addition, with the combination of FlexE bonding and DWDM, the SPN system can support single-fiber with Terabit-level capacity.

### 3.3 Deterministic Low Latency Technology

The deterministic ultra-low latency requirement is an important change in 5G services, compared with the LTE era. eMBB services require 10 ms E2E latency and URLLC services require 1 ms E2E latency, which poses higher requirements than LTE services.

When forwarding service packets, traditional packet devices place packets in queues on outbound interfaces, resulting in long latency of tens of  $\mu$ s. In case of network congestion, latency is longer and even reaches the millisecond level, which cannot meet the requirements of low-latency services in the 5G era. The 5G URLLC service requires the low forwarding latency at the  $\mu$ s level and low delay jitter on a single node.

#### 3.3.1 Packet Low Latency

The packet low latency forwarding technique improves the forwarding mechanism that rapidly forwards packets which are identified as low latency packets, and do not need queue processing. If an outbound interface is forwarding other packets with lower priorities, the low-latency services can preempt resources and are rapidly forwarded in real time.

Figure 3-4: Fast packet forwarding

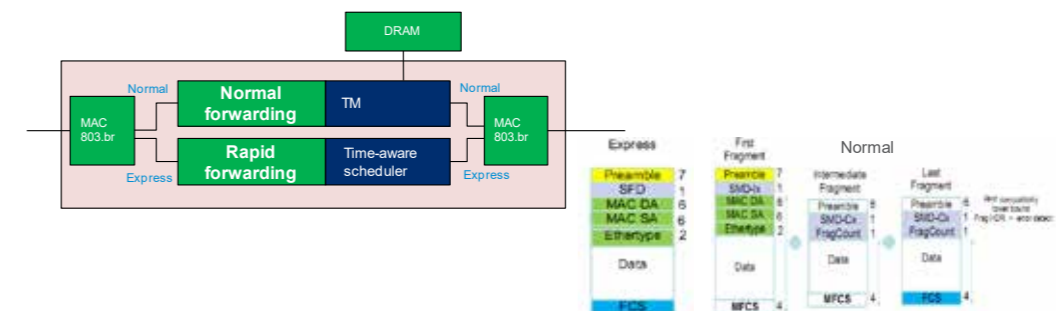

The fast packet forwarding technique reduces the forwarding latency of a sin-

gle node to the 10 μs scale.

### 3.3.2 Slicing Ethernet Low Latency Technology

Traditional packet devices forward customer service packets hop by hop. On each node, those Packets experiences PHY layer processing, packet assembly, addressing and label lookup for forwarding, and queue scheduling before it was transmitted. The processes induce unpreventable random high node latency up to dozens of microseconds. Even with the packet fast forwarding mechanism, node latency is reduced at certain level but end-to-end latency variation (jitter/PDV) still cannot meet the requirements of latency-sensitive 5G services. Therefore, a further latency optimization solution targeting at deterministic low latency needs to be considered.

The slicing Ethernet-based deterministic low latency solution has introduced SE-XC technologies to replace the traditional store-and-forward mechanism. User packets do not need to be parsed on intermediate nodes of a network, and the service flow forwarding process is almost completed in real time. The node latency of a pizza box device can be optimized to the microsecond level.

For instance, a PE maps user service packets to SPN channels. The intermediate node performs SE-XC and then directly forwards the service packets to the outbound interface without the time consuming queuing process. Therefore it could achieve extremely low forwarding latency.

Figure 3-5: Figure 3-5 SE-XC principles

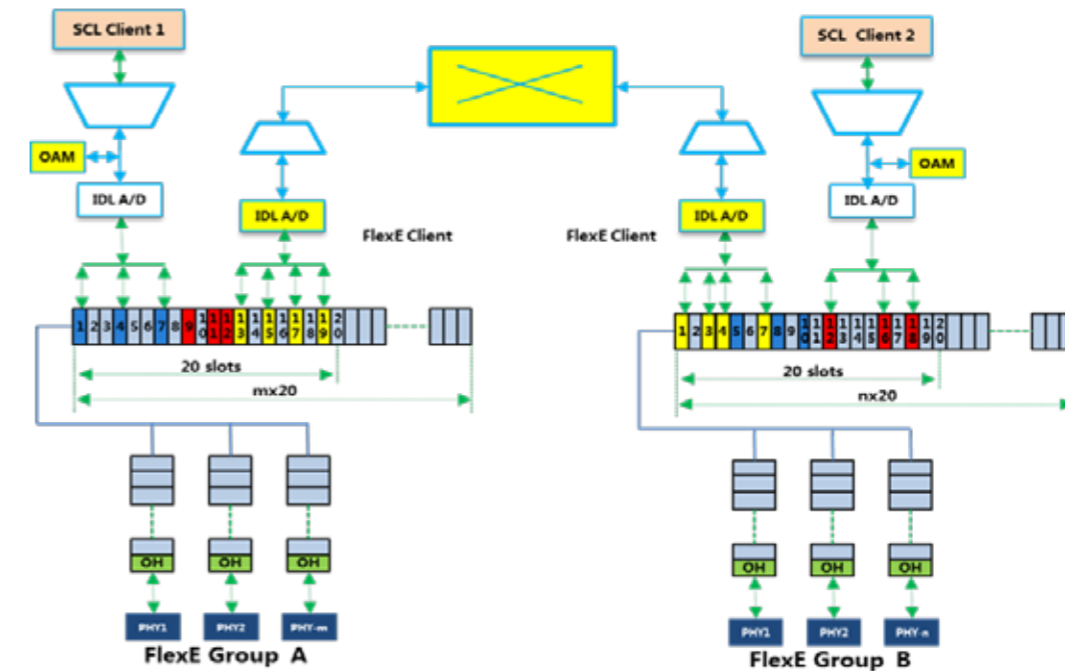

The preceding figure shows the SPN channel switching process. FlexE Groups A and B indicate two logical interfaces on a device. Each group can have m physical links. Assume that three FlexE client services are configured.

- Client1 in blue is mapped to the timeslots 1, 4, and 7 and switched to the timeslots 5, 8, and 10 on the right.
- Client2 in red is mapped to the timeslots 12, 16, and 18 and switched to the timeslots 9, 11, and 12 on the left.
- Client3 in yellow is a pass-through service, which is mapped to the timeslots 13, 15, 17, and 19 on the left and switched to the timeslots 1, 3, 4, and 7 on the right.

For the pass-through service in yellow, Group A receives code blocks from m PHY chips and restores the m x 20 code block sequences. Group A extracts code blocks from timeslots 13, 15, 17, and 19 based on the preconfigured timeslot table and restores the code block stream of Client3. Then, the code blocks are inserted into the timeslots 1, 3, 4, and 7 in the m x 20 code block sequences on the right, implementing the SPN channel switching. Finally, the code blocks are forwarded to the next node through the PHY chips.

The SE-XC-based forwarding technology implements service forwarding at the timeslot layer. Similar to the L1 forwarding technology, SE-XC ensures that the minimum delay is less than 1  $\mu$ s, and the jitter is very small, which is suitable for carrying URLLC services. SE-XC meets the stringent requirements on latency and jitter for services, such as financial high-frequency transactions and autonomous driving.

### 3.4 Flexible and Reliable Connection Technology

#### 3.4.1 Flexible Connection Requirements

The 5G mobile backhaul is deployed with the flat IP architecture. The east-west traffic between base stations soars due to the requirements of ultra-dense networking. In addition, deploying MEC downstream requires the setup of east-west channels between different MECs. The number of 5G network connections increases dozen-fold compared with the number of 4G network connections. Traditional static MPLS-TP tunnels cannot meet the requirements of flexible service scheduling and ubiquitous connections. Therefore, a new tunnel connection technology is required.

#### 3.4.2 Flexible Connection Technology

As a source routing technology, segment routing (SR) simplifies the existing MPLS technology, reuses the existing MPLS forwarding mechanism, is compatible with the current MPLS network, and supports smooth evolution from the existing MPLS network to the SDN network. SRTP is a new tunnel technology that enhances O&M capabilities in the transport domain based on the SR tunnel technology. It is classified into SRTP-TE tunnel or SRTP-BE tunnel.

- SRTP-TE Tunnel

A traditional SR-TE tunnel does not require the maintenance of the path status on a transit node, therefore improving flexibility of tunnel path adjustment and network

programmability. However, SR-TE only maintains path information on the source node, making it impossible for bidirectional association. In this case, SR-TE lacks the traditional transport-gear capabilities of end-to-end OAM detection and bidirectional tunnels.

An SRTP-TE tunnel uniquely identifies an end-to-end connection by carrying a path segment and implements bidirectional tunnels by path segment association. As a subset of the SR-TE tunnel, the SRTP-TE tunnel features SR-TE's flexible features and the transport capability of traditional tunnels. SRTP-TE is an ideal evolution solution for MPLS-TP tunnels on the existing transport network.

Figure 3-6: SRTP-TE Tunnel

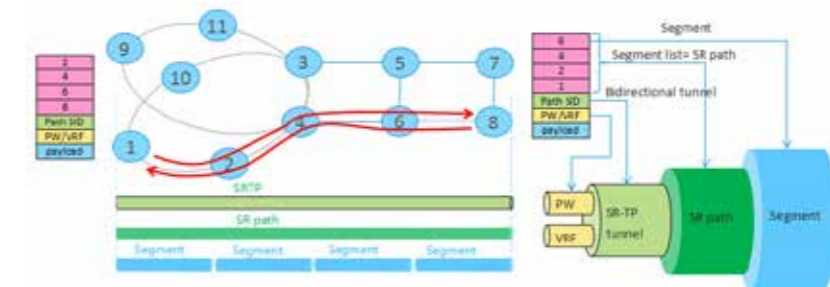

- SRTP-BE Tunnel

An SRTP-BE tunnel is automatically generated after an IGP flooding. Full-Mesh tunnel connections can be generated in the IGP domain. SRTP-BE tunnels are applicable to connectionless Mesh services and simplify tunnel planning and deployment.

### 3.5 Ultra-High Precision Synchronization Technology

#### 3.5.1 High-Precision Time Synchronization Requirements

5G divides traditional BBU into two logical entities: CU and DU. CU devices process non-real-time wireless upper-layer protocol stacks, and DU devices process physical layer functions and real-time requirements. Time synchronization requirements

for CU and DU are different. CU devices do not require precise time synchronization, while the DU-AAU level has the following synchronization requirements:

**(1) Synchronization for the 5G TDD basic service**

For TDD base stations, uplink and downlink signals utilize the same frequency. To prevent signal interference between base stations, strict phase synchronization between base stations must be satisfied to ensure that the uplink-downlink switching time on all the base stations is consistent. The introduction of ultra-short frames to 5G New Radio (NR) speeds up the uplink-downlink switching frequency, which requires the time synchronization accuracy to the microsecond level.

**(2) Synchronization for the coordination technologies between base stations**

The coordination technology is an enhanced attribute for 5G, which has strict requirements on the time error, e.g. base station coordination (CoMP) and base station carrier aggregation (CA) requires the time precision of about  $\pm 130$  ns, whereas the evolution of the MIMO technology proposes the synchronization accuracy requirement of  $\pm 65$  ns.

**(3) Synchronization for new 5G services**

For TDOA-based base station positioning services, the positioning precision is linearly related to the time error between base stations. The 1-ns time error corresponds to the positioning precision of about 0.3 m to 0.4 m, and the 3-m positioning precision corresponds to the time error of about 10 ns.

Considering 5G service evolution requirements, 5G has higher synchronization precision requirements than  $\pm 1500$  ns of the 4G TD-LTE technology.

### 3.5.2 SPN Time Synchronization Network Model

The time error allocation on the time distribution chain for the 4G network is as follows.

**Table 3-1:** The time error allocation for the 4G network

Time Reference Source	Transport Network	Base Station	E2E Synchronization budget
$\pm 250$ ns	$\pm 1000$ ns	$\pm 250$ ns	$\pm 1500$ ns

For the 5G SPN, considering the synchronization requirements and future technology evolution and the balance between difficulty and cost, the time error allocation is suggested as following table.

**Table 3-2:**The time error allocation for the SPN

Time Reference Source	Transport Network	Base Station	E2E Synchronization budget
$\pm 50$ ns	$\pm 200$ ns	$\pm 50$ ns	$\pm 300$ ns

The 200 ns budget for the transport network can be allocated as follows:

(1) 100 ns for normal time synchronization. Each node is assigned  $\pm 5$  ns. A total of 20 hops are supported for a time chain.

(2) 100 ns for time holdover during a fault.

Ultra-high precision time synchronization is required for 5G fronthaul, midhaul, and backhaul networks.

### 3.5.3 Ultra-High Precision Synchronization Technology for the SPN

Ultra-high precision time synchronization requires new time source and time transmission technologies. In order to support the new network architecture, new synchronization interface, maintenance and management technologies are required.

**(1) Ultra-High Precision Time Reference Source**

The ultra-high-precision time reference source needs to achieve the synchronization accuracy better than  $\pm 50$  ns. The following technologies can be used to enhance the accuracy:

- New satellite receiving technology

Possible solutions for reducing the GNSS receiving time error include using the GNSS common-view method or dual-band GNSS receiving technology.

- High-stability frequency source technology

The introduction of the clock group (such as a rubidium clock group) instead of a single clock improves the stability and the holdover performance without GNSS.

### (2) Time Transmission Technology

In the time transport process, the time error sources come from the following:

- Time stamping granularity
- Physical-layer frequency error
- PHY-layer asymmetry
- Propagation delay inside a node
- Link asymmetry

To achieve ultra-high precision time synchronization, the following techniques are available:

- The high-precision timestamp technology enables the time stamping granularity to be better than  $\pm 1$  ns.
- The clock module with high stability and synchronization precision provides more precise and stable frequency.
- Precise latency measurement and compensation for the PHY layer.
- Precise latency design and measurement for the system.
- Precise latency measurement and control for asymmetric links. This problem can be solved by using single-fiber bidirectional transmission.
- Enhanced synchronization test protocols and algorithms with higher precision.

### (3) Synchronization Interface Technology

The SPN should support dedicated synchronization interfaces and novel in-band interfaces with ultra-high precision.

- Dedicated synchronization interface with ultra-high precision

The dedicated synchronization interface is used for the time source input, the time output and measurement. The following interfaces could be considered:

(a) 1GE optical synchronization interface: used to access ultra-high precision time sources and transmit time information to downstream devices.

(b) 1PPS synchronization output interface: used to output the 1PPS signals of the local node, facilitating the measurement using the synchronization test device.

es.

- Novel in-band synchronization interface

Since the SPN utilizes new traffic interfaces, accordingly it must support new synchronization interface technologies:

a) FlexE interface synchronization: supports ultra-high precision time synchronization and interworking.

b) eCPRI interface synchronization: Ethernet interface synchronization is used to implement eCPRI interface synchronization and interworking.

### (4) Intelligent Clock Technology

The intelligent clock technology at the control layer provides the support for the deployment and O&M of ultra-high precision synchronization networks. The core functions are as follows:

- Automatic planning of the synchronization network
- Graphical display of the dynamic synchronization status
- Detection and analysis of the synchronization running status
- Intelligent synchronization fault diagnosis
- Real-time monitoring and analysis of the synchronization performance

## 3.6 Centralized Management and Control Technology of SDN

### 3.6.1 Requirements

SDN is one of the key 5G technologies. It can be summarized as centralized network control, separation of forwarding and control, open network and programmability. SDN uses a three-layer architecture (service application layer, network control layer, and forwarding layer) to improve 5G network resource utilization, accelerate service deployment, and enable flexible service scheduling as well as open network programmability.

The SDN controller, as an intelligent network operating system, has the following development trends:

#### (1) E2E management capability

The SDN technology allows the SPN to transform from vertical management



of individual NEs, networks, and services to closed-loop management covering deployment of network and service to evaluation feedback. The operating system forms a closed-loop process from service creation, network monitoring, fault analysis, and performance evaluation to network fault switchover and recovery. This greatly improves service deployment efficiency and network robustness.

**(2) Automated OAM and analysis**

To cope with dynamically changed services, the intelligent operating system must transform towards automated management to agilely manage network functions, applications, and services. This capability automatically generates OAM policies based on the Big Data analytics of the 5G network.

**(3) Open operating capability**

Another important principle of intelligent operations is to break through the technical barriers of different vendors and build an open platform for unified management and control. The free and open-source software architecture and the carrier network capabilities open to third parties can accelerate the maturity and commercial use of new technologies and boost innovation.

**3.6.2 Key Technologies for Intelligent Operations**

To adapt to the changes of the SPN architecture, the new intelligent operations system must make changes in key technologies such as service architecture, service model and policy, operations process, and reliability and security assurance. The following figure shows the mapping between the development trend of intelligent operations and key technologies.

**Figure 3-7: Key technologies for intelligent operations**

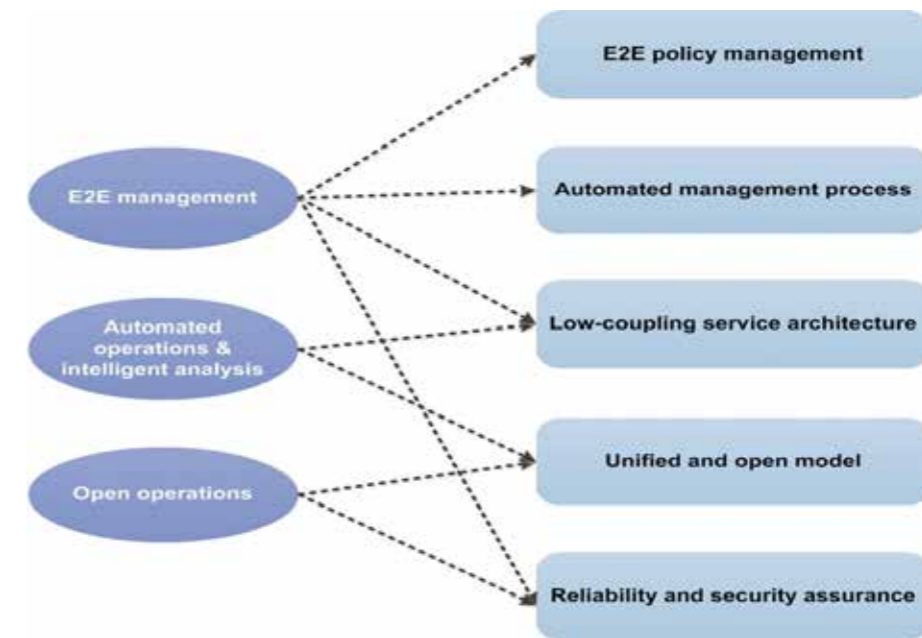

**(1) Low-coupling service architecture**

The core idea of the low-coupling service architecture is to atomize various independent functional modules into independent atomic services, so that providing different service scenarios through aggregation and combination. Atomic functions are classified into different types based on basic service functions. The orchestrator or controller arranges and combines sub-functions as required for different service scenarios.

**(2) Automated management process**

Standardization and automation of design, creation, deployment, management, and iteration of new services based on the advantages of the SDN network architecture can greatly improve network operations efficiency. Automated management involves automated service configuration, automated environment awareness, automated software and hardware installation and upgrade, automated fault detection, automated service switchover and recovery, intelligent service data analysis, and so on.

**(3) E2E policy management**

A policy management module can be developed to formulate, parse, execute, and optimize policy rules for automated orchestration. The orchestrator can deliver policies to the unified policy library based on design requirements. Once a network event occurs, the controller or orchestrator can automatically perform pre-defined actions to reduce manual intervention and increase the response speed.

**(4) Design of unified open model**

A set of standard data models are the prerequisite for E2E service management, data analysis, and an open operations platform. Based on standard specifications, the formulated models and process of unified topology reporting, alarm & performance reporting, and service configuration can significantly reduce E2E service differences. In addition, the data analysis system can extract key information and analyze data based on these fixed models.

**(5) Reliability and security assurance**

The orchestrator and controller, as the core of the operations system, must guarantee reliability of the intelligent operating system for providing timely E2E management. By dividing a network into multiple subnets and allocating each subnet to multiple controller clusters for management and control, the cluster deployment and distributed storage solution improves network robustness and prevents single point failure or single point traffic congestion.

**3.6.3 Architecture of the Intelligent Operating System**

The following figure shows the architecture of an SPN-based intelligent operations system. The core module is the SDN controller, which provides intelligent operations through centralized control and management of network devices.

**Figure 3-8: Architecture of intelligent operating system**

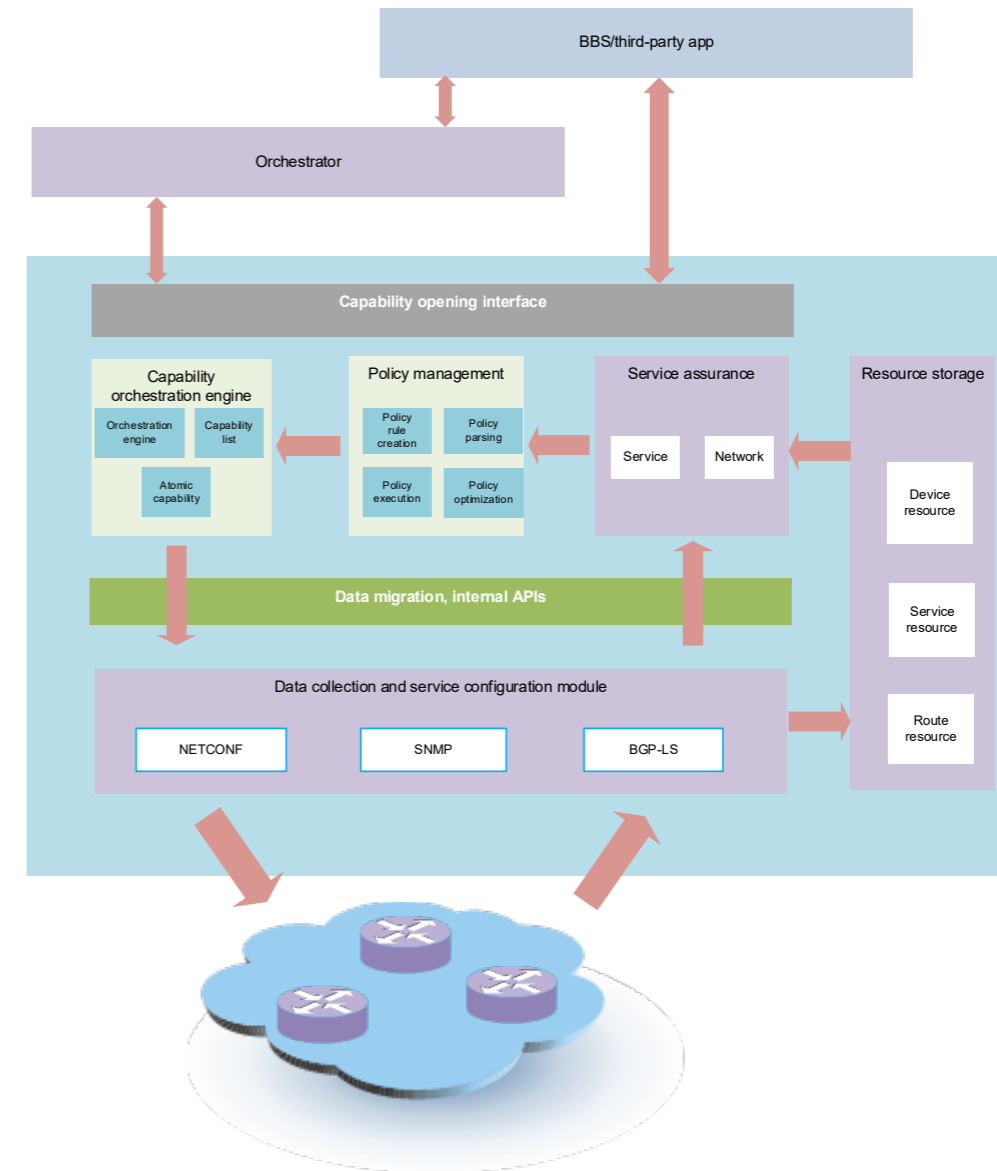



Being the next-generation integrated transport network technology, the SPN is applicable to diversified application scenarios. Based on brand-new network architecture, multiple key technologies and new operation mode, SPN is a good choice for the user to carry multiple services on an integrated transport network in the 5G era.

### 4.1 Mobile Service Transport

The unified transport of fronthaul, midhaul and backhaul services enabled by the SPN prevents heterogeneous networks from interoperation, which not only makes the entire network planning, provisioning, O&M, and optimization much easier, but also reduces the network CAPEX and OPEX greatly. The architecture of the SPN-based mobile transport network is as shown in Figure 4-1.

Figure 4-1: Mobile Transport

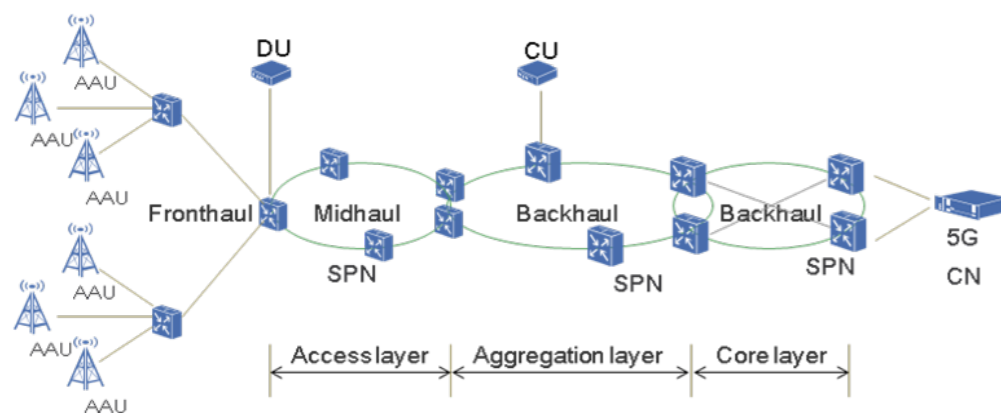

#### 4.1.1 Fronthaul Network

In CRAN scenarios where the DUs or integrated DUs and CUs are deployed in a centralized manner, the network between the AAUs and the DUs or integrated DUs/CUs is referred to the fronthaul network. The fronthaul network requires high bandwidth (more than 20 Gbit/s per AAU) and low latency (less than 100 μs).

The SPN provides the following features for fronthaul network:

- The ultra-low-latency service forwarding based on the SPN channel

cross-connect technology of the SCL satisfies the 5G fronthaul network's demand for low latency.

- Complete OAM and protection mechanisms enable real-time fronthaul network monitoring, swift fault localization and fast protection switchover.
- Low-cost 100GE short-distance silicon optical modules are employed to reduce network construction costs.
- The industry-leading CPRI over FlexE technology provides compatibility with traditional 3G/4G fronthaul interfaces.

#### 4.1.2 Midhaul/Backhaul Network

The 5G base stations can be deployed in different ways. For example, the DUs and CUs can be deployed together or separately. If the DUs and CUs are deployed together, the transport network needs to transmit services to the core network. If the DUs and CUs are separately deployed, the midhaul network completes service transmission between the DUs and CUs, and the backhaul network transport services from the CUs to the core network. Both deployment methods may coexist.

Despite of different deployment ways, the 5G base station raise unified demands for the transport network, including: high bandwidth, low latency (lower than that of 4G networks), stronger L3 routing capabilities, L3 to edge, and flexible deployment and scheduling of southbound, northbound, and east-west services.

An SPN-based metro network consists of three layers (access, aggregation and core layers), implementing unified transport of the midhaul and backhaul services.

### 4.2 Data Center Interconnection

In the future, DCs will be more widely used to carry various NFV cloud software and IT applications, playing a pivotal role in carrier service deployment. At the same time, service interoperation between different DCs will be more complicated. The SPN-based integrated transport network can be used to interconnect the DCs.

### 4.2.1 Multi-point Interconnection Between Edge DCs over the SPN

When multiple DCs exist in one MAN, mesh networking is required. The SPN can be employed to provide independent network slicing to carry the DCI services. The DC GWs interconnect each other via SPN L3 VPN, which satisfies the requirements of the inter-DC traffic scheduling.

Figure 4-2: Interconnection between edge DCs

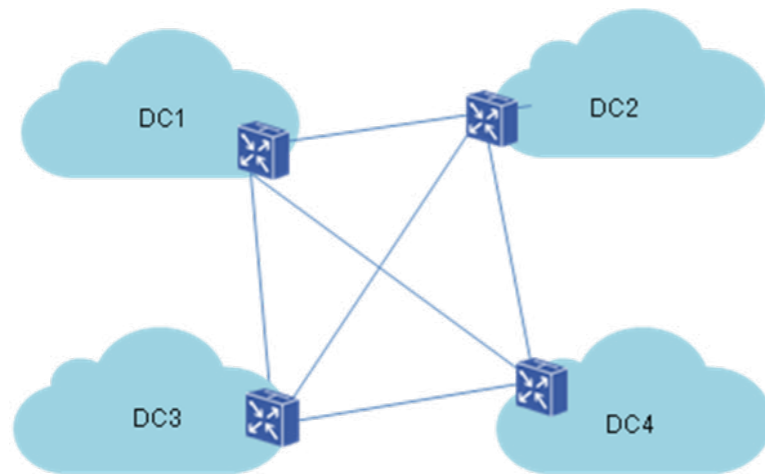

### 4.2.2 Point-to-Point Interconnection Between DCs over the SPN

For point-to-point interconnection between DCs in a metro area, the SPN can provide L1 transparent transport with CBR mapping and high-bandwidth hard pipes so as to ensure low latency for DC services.

Figure 4-3: Interconnection between VDCs

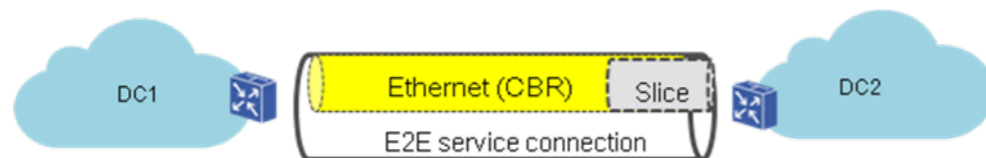

### 4.3 Video Everywhere

With the increasing popularity of the Internet, video services provide an important strategic transformation opportunity for telecom carriers. In the era of big video, UHD videos such as 4K, 8K, and VR/AR raise higher requirements for the network bandwidth, latency, and jitter. The telecom carriers can leverage their network advantages to provide video services with higher quality and better user experience than Internet OTT players.

To transfer home broadband services such as HSI and IPTV running on optical line terminals (OLTs), the SPN employs the SPN channel to partition the network into multiple independent slices. The services on different slices are isolated from each other. As per real-time traffic status, the SPN can deploy QoS to set priorities for different services. So that, the video services can get corresponding precedence. To prevent IPTV service performance degradation caused by network congestion, the independent network slicing technology can be used to carry IPTV services. In this way, these IPTV services are strictly isolated from common Internet access services, making the users enjoy highly qualified services that are quite different from other OTT services. The service quality measurement (SQM) technology is used to monitor video traffic performance, including the latency, bandwidth and jitter. Based on statistics and analysis implemented on a regular basis, the network can be changed accordingly to ensure the service quality.

Figure 4-4: SPN-based big video service transport

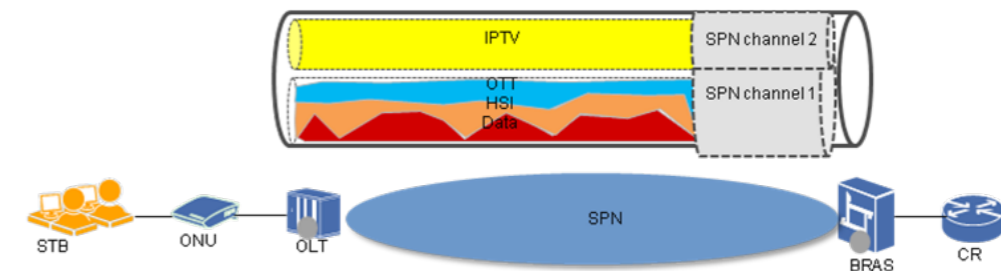

With the development of big video services, the upstream bandwidth of an OLT has expanded from NxGE to Nx10GE. The SPN that can be expanded via the FlexE and DWDM technologies provide bandwidth guarantee for home broadband services.

### 4.4 Cloud Private Line

Being an excellent combination of the SDN technology and packet transport network, the SPN is capable of implementing fast network re-architecting, providing suitable network slices for private lines and offering cloud connection. The SPN can also address cloud application requirements by connecting DCs or deploying local computing nodes.

#### 4.4.1 Cloud Connection

The SPN can be divided into network slices based on resources such as ports, wavelengths, and FlexE channels. A physical network can be divided into multiple virtual networks, with each virtual network carrying respective private service without affecting each other.

Also, the SPN can provide differentiated L2/L3 services based on the actual requirements of enterprise users. This allows flexible service scheduling between enterprise branches and the headquarters and provides customers with L2VPN/L3VPN capabilities.

Figure 4-5: Cloud connection

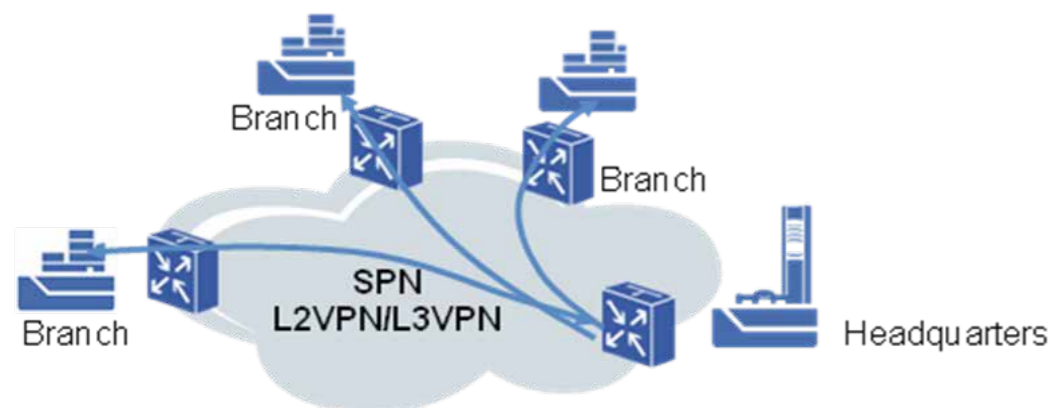

Private line services with higher requirements for isolation, such as Ethernet and SDH services for finance and securities sectors, can be carried by SPN channel-based hard pipes independently. The client side of the SPN device uses CBR

mapping to directly forward the bit streams at the physical layer to the SPN channels, and the intermediate nodes of the network service uses SE-XC for service scheduling. This implementation meets the requirements for hard service isolation, security, and ultra-low latency.

Figure 4-6: CBR private line of the SPN

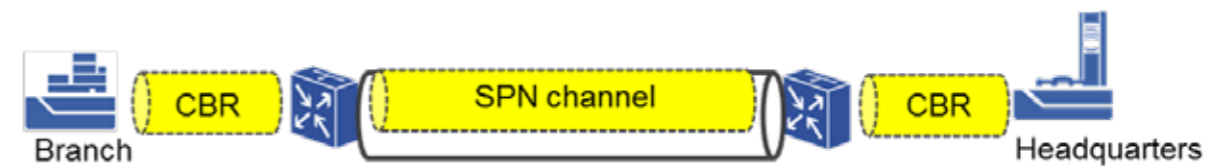

#### 4.4.2 Cloud Application

In private line service scenarios involving cloud-and-network synergy, the user-side CPE enables user access and enterprise virtualization services. Or access enterprise branches to provide virtual private line connections.

The user services access the DC user gateway vMSR via the SPN for Internet and site access. The switches in branches connect the SPN through L2 VLANs, and the SPN transmits the services to the TOR switches on leaf nodes of the DC. The DVS directs the L2 traffic to the vMSR

Figure 4-7: Cloud-and-network synergy

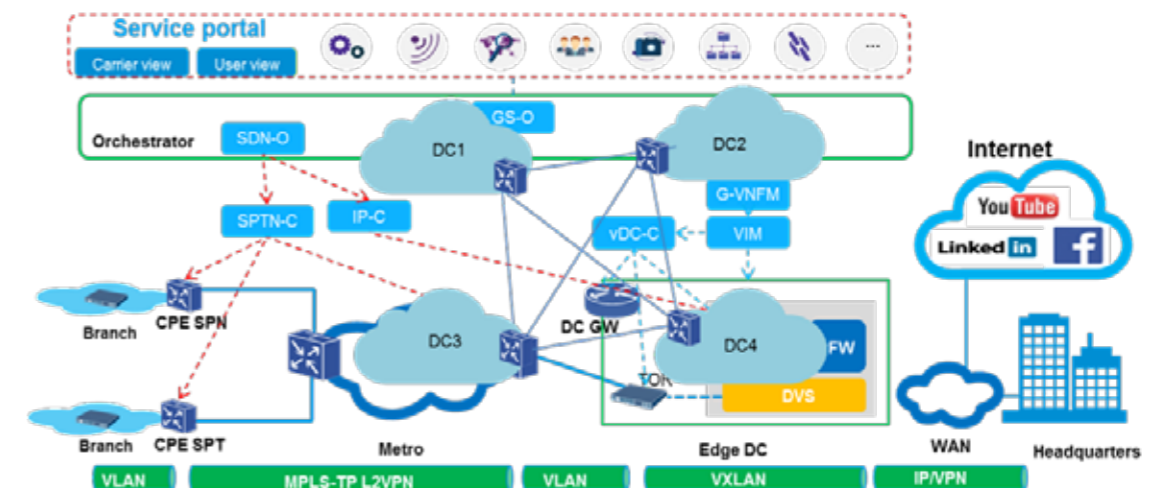



The SPN 5G transport solution, which adheres to the vision of “New Architecture, New Services, and New Operations”, supports brand-new cloud service transport and agile network operation. The SPN uses an efficient Ethernet ecosystem to provide low-cost and high-bandwidth transport channels. By effectively integrating multi-layer network technologies, the SPN enables the transmission of L0-L3 services and soft/hard pipe slicing. Also via the SDN-based centralized management and control, it presents an open, agile, and efficient network operation system to the user.

In addition to in-depth research, China Mobile also verified the SPN network architecture and key technologies in labs. From August to December 2017, China Mobile Research Institute (CMRI) organized major equipment vendors to complete the lab tests of SPN prototypes. The test covers a variety of items, for instance, STL, SCL, and SPL, time synchronization and interoperation between different vendors. The test results show that the SPN is able to meet the requirements for integrated transporting 5G and other MANs’ services.

In 2018, China Mobile will conduct small-scale 5G service transport field trial in multiple cities to promote SPN commercialization, so that SPN can be commercially used on a large scale in 2019.

At the ITU-T SG15 plenary meeting held at Geneva, Switzerland from January to February in 2018, a project initiation is approved for the Characteristics of Transport Networks to Support IMT-2020/5G (G.ctn5g) standard, which marks a new phase of ITU-T’s 5G transport research. The SPN technology is regarded as an important part of the standard.

The year 2018 marks the beginning of 5G transport, China Mobile is ready to strengthen cooperation with global 5G organizations, enterprises, research institutes, and universities to promote the research of SPN architecture and key technologies, and boost the development of SPN standards and the industry.

## Abbreviations

IPPS	1 Pulse Per Second
AAU	Active Antenna Unit
AI	Artificial Intelligence
AR	Augmented reality
ARPU	Average Revenue Per User
BGP-LS	Border Gateway Protocol – Link State
CAPEX	Capital Expenditure
CBR	Constant Bit Rate
CoMP	Coordinated Multiple-Point Transmission/Reception
CPE	Customer Premise Equipment
CPRI	Common Public Radio Interface
CRAN	Cloud Radio Access Network
CU	Centralized Unit
DC	Data Center
DCI	Data Center Interconnect
DC-GW	Data Center Gateway
DU	Distributed Unit
DVS	Digital Video Server
DWDM	Dense Wave-length Division Multiplexing
E2E	End to End
eMBB	Enhanced Mobile Broadband
FEC	Forward Error Correction
FlexE	Flexible Ethernet
HD	High Definition
HSI	High Speed Interaction
ICT	Information Communication Technology
IDC	Internet Data Center
IGP	Interior Gateway Protocol
IMT-A	International Mobile Telecommunications Advanced
IoT	Internet of Things
IoV	Internet of Vehicles
IP	Internet Protocol
IPTV	Internet Protocol TeleVision
IS-IS	Intermediate System-to-Intermediate System



IT	Information Technology
ITU	International Telecommunication Union
L2VPN	Layer 2 Virtual Private Network
L3VPN	Layer 3 Virtual Private Network
LTE-A	Long Term Evolution Advanced
MAC	Media Access Control
MEC	Mobile Edge Computing
MIMO	Multiple-Input Multiple-Output
mMTC	Massive Machine Type Communication
MP2MP	Multi-Point to Multi-Point
MPLS	Multi-Protocol Label Switching
MPLS-TP	MPLS Transport Profile
MSR	Multi-Service Router
NE	Network Element
NFV	Network Function Virtualization
NNI	Network Network Interface
NR	New Radio
O&M	Operation and maintenance
OAM	Operation, administration and maintenance
OIF	Optical Internetworking Forum
OLT	Optical Line Terminal
OPEX	Operating Expense
OTT	Over The Top
P2P	Point to Point
P2MP	Point to Multi-Point
PAM4	Four-Level Pulse Amplitude Modulation
PCEP	Path Computation Element Protocol
PCS	Physical Coding Sub-layer
PHY	Physical Layer
PMA	Physical Media Attachment
PMD	Physical Media Dependent
PTN	Packet Transport Network
QoS	Quality of Service
ROI	Return on Investment
SCL	Slicing Channel Layer
SDN	Software Defined Network
SE	Slicing Ethernet

SE-XC	Slicing Ethernet Cross Connection
SLA	Service-Level Agreement
SPL	Slicing Packet Layer
SPN	Slicing Packet Network
SR	Segment Routing
SR-BE	Segment Routing - Best Effort
SR-TE	Segment Routing - Traffic Engineering
SRTP	Segment Routing Transport Profile
SRTP-BE	Segment Routing Transport Profile - Best Effort
SRTP-TE	Segment Routing Transport Profile -Traffic Engineering
STL	Slicing Transport Layer
TDD	Time Division Duplex
TDM	Time Division Multiplexing
TM	Traffic Management
TOR	Top Of Rack
UHD	Ultra High Definition
UNI	User Network Interface
URLLC	Ultra Reliable & Low Latency Communication
VR	Virtual Reality
VLAN	Virtual Local Area Network
WAN	Wide Area Network